

BUG-PHI-2

Designed for Philips PageWriter TC10 cardiograph

-  Ergonomic
-  Easy to clean
-  Multi purpose
-  Lifetime warranty
-  Quick setup



FEATURES



Designed and manufactured in Hungary, products are typically 100% recyclable and upgradable in the future. Raw materials are sourced locally or in the EU.



Mounting for device



Channels to fix accessories



Lockable wheels

Cart Properties

Dimensions and mechanical data

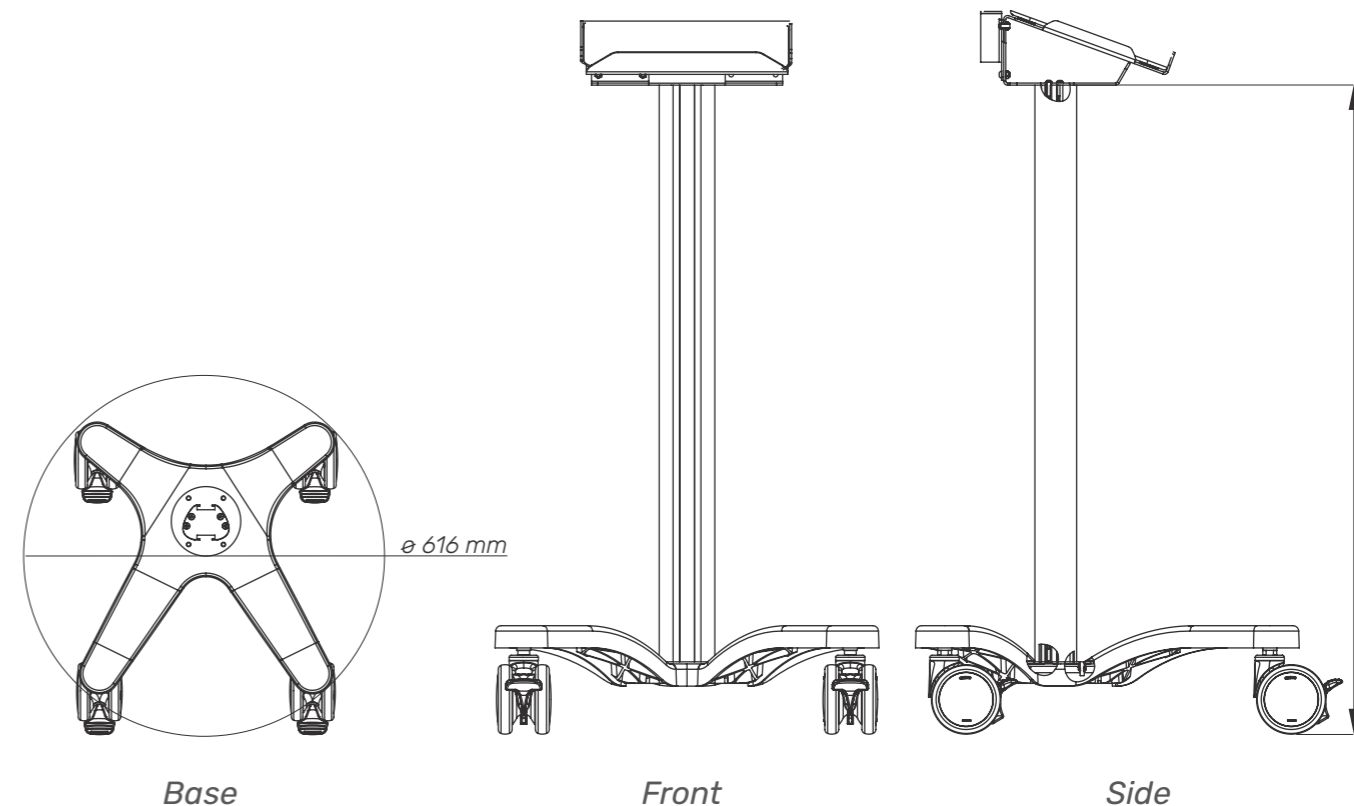

Mechanical data	
Height	1100 mm
Wheelbase dimension	616 mm (diameter)
Wheel construction	Polyamide with Polyurethane tread
Wheels/locking	2 lockable, 100 mm diameter
Loading capacity	25 kg
Construction	
Main material	Aluminium
Color	
RAL 9016	
Custom color	
Certificates	
Certificates conforms to	IEC60601-1:2012 (Edition 3)
CE	Rohs compliant