

# RHI-O-N

Heavy duty cart with transformer holder  
and DIN rails  
**Rhino Range**



*Ergonomic*



*Easy to clean*



*Multi purpose*



*Lifetime warranty*



*Quick setup*



## FEATURES



*Designed and manufactured in Hungary, products are typically 100% recyclable and upgradable in the future. Raw materials are sourced locally or in the EU.*



*DIN Rail for additional equipments*

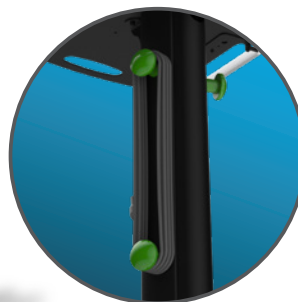

*Cable management on and in the column*



*Transformer holder*

# Cart Properties

## Dimensions and mechanical data

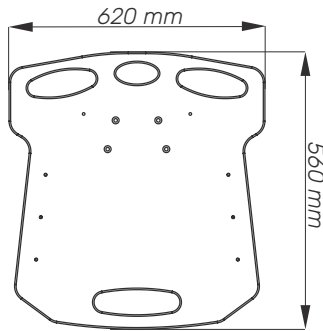

Worksurface

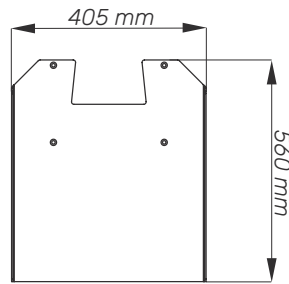

Shelf

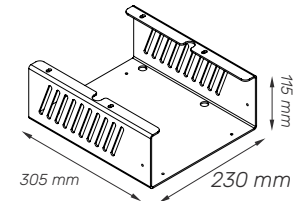

Transformer holder

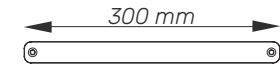

DIN Rail

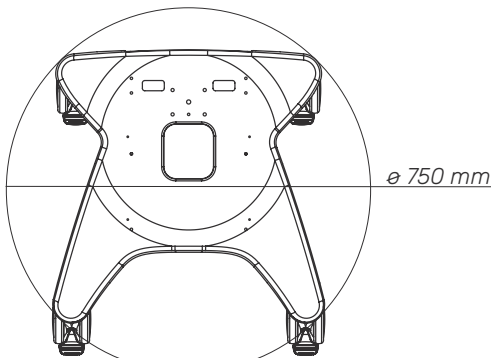

Top

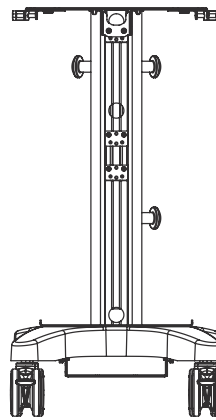

Front

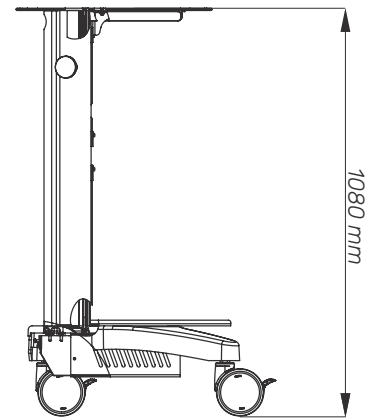

Side

### Mechanical data

Height	Min.: 865 mm Max.: 1200 mm
Wheelbase dimension	750 mm (diameter)
Work surface dimensions	Width: 620 mm Height: 560 mm
Wheels/locking	2 lockable, 125mm diameter
Loading capacity	80 kg
Shelf	405x560 mm
Transformer holder	230x115x305 mm
DIN Rail	300 mm

### Construction

Main material	Aluminium
---------------	-----------

### Color

RAL 9016	
Custom color	

### Certificates

Certificates conforms to	IEC60601-1:2012 (Edition 3)
CE	Rohs compliant