

# RHI-3-0127

Height adjustable cart with power pack, display mount, keyboard tray and power supply holder

## Rhino Range



*Ergonomic*



*Easy to clean*



*Multi purpose*



*Lifetime warranty*



*Quick setup*

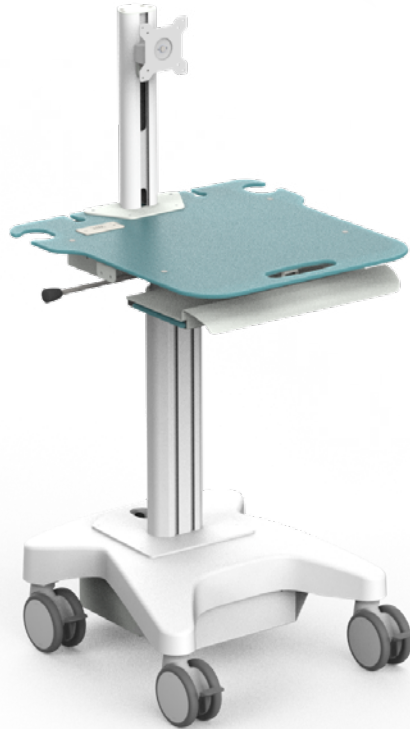

## FEATURES



*Designed and manufactured in Hungary, products are typically 100% recyclable and upgradable in the future. Raw materials are sourced locally or in the EU.*



*Battery Pack with power management software*



*Display mount*

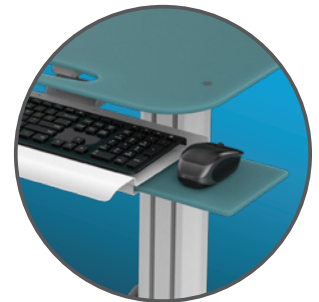

*Keyboard tray*

# Cart Properties

## Dimensions and mechanical data

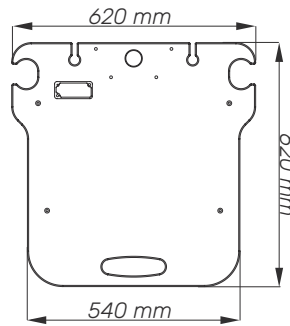

Worksurface

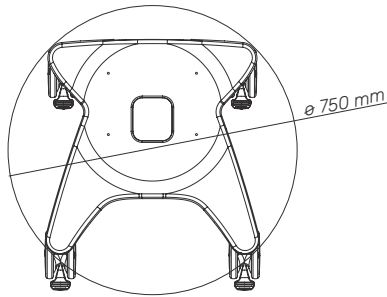
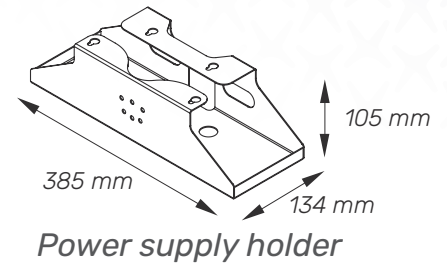

Base

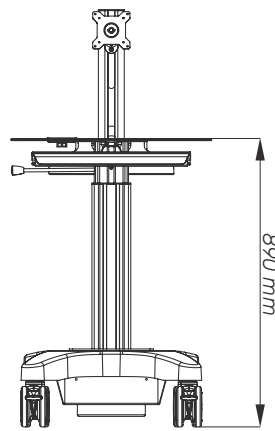

Front

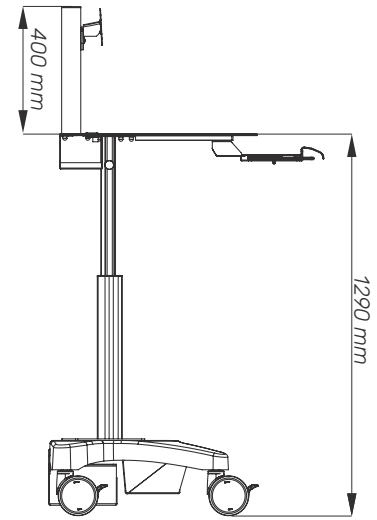

Side



### Mechanical data

Height	Min.: 890 mm - Max.: 1290 mm
Wheelbase dimension	750 mm (diameter)
Work surface dimensions	Width: 620 mm Height: 620 mm
Wheels/locking	4 lockable, 125 mm diameter
Loading capacity	80 kg
Cart weight	45 kg
Battery	512 Wh, LiPo4

### Construction

Main material	Aluminium
---------------	-----------

### Color

RAL 9016	
Custom color	

### Certificates

Certificates conforms to	IEC60601-1:2012 (Edition 3); U38.3; IEC62133
CE	Rohs compliant