

RHI-3-0131

Heavy duty cart with Display mount,
Shelves, DIN Rails and Transformer holder
Rhino Range



Ergonomic



Easy to clean



Multi purpose



Lifetime warranty



Quick setup



FEATURES



Designed and manufactured in Hungary, products are typically 100% recyclable and upgradable in the future. Raw materials are sourced locally or in the EU.

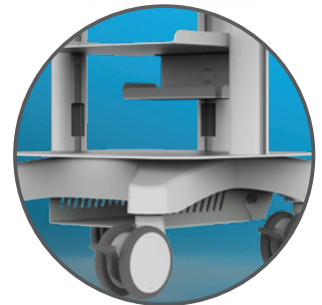

Transformer holder & power supply holder with cable management in the columns



Display mount

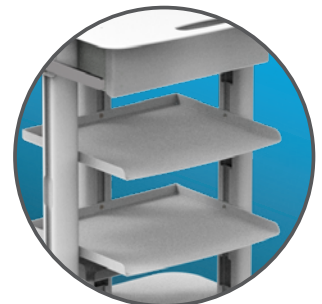

Shelves

Cart Properties

Dimensions and mechanical data

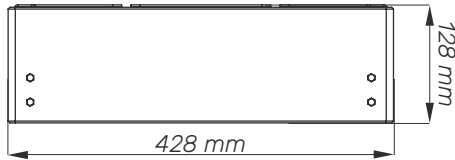

Drawer (Depth: 325 mm)

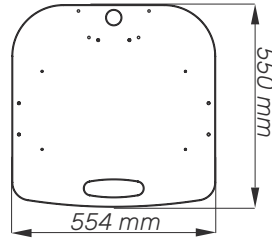

Worksurface

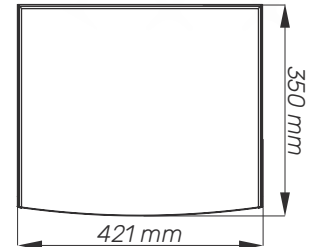

Shelves

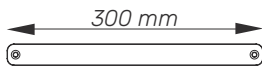

DIN Rail

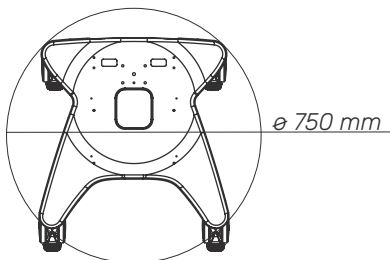

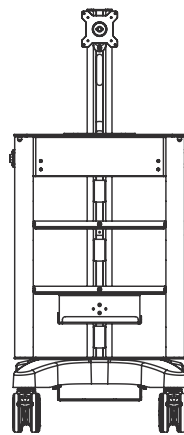

Base

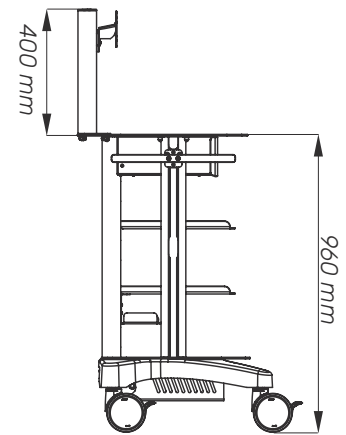

Front



Side

Mechanical data	
Height	1200 mm
Wheelbase dimension	750 mm (diameter)
Work surface dimensions	Width: 554 mm Height: 550 mm
Wheels/locking	2 lockable, 125mm diameter
Loading capacity	80 kg
VESA Mount hole pattern	75x75 mm; 100x100 mm
VESA Mount load capacity	6-12 kg
Construction	
Main material	Aluminium
Color	
RAL 9016	
Custom color	
Certificates	
Certificates conforms to	IEC60601-1:2012 (Edition 3)
CE	Rohs compliant