

RHI-3

Height adjustable cart
with laptop mount

Rhino Range



Ergonomic



Easy to clean



Multi purpose



Lifetime warranty



Quick setup



FEATURES



Designed and manufactured in Hungary, products are typically 100% recyclable and upgradable in the future. Raw materials are sourced locally or in the EU.

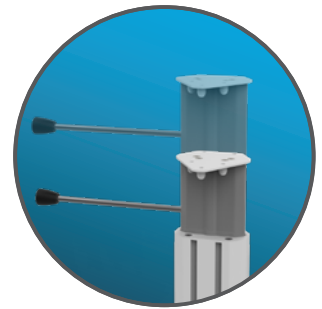

*Height adjustment
and column channels
to fix accessories*

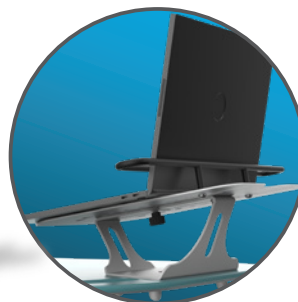

Laptop protection



Lockable wheels

Cart Properties

Dimensions and mechanical data

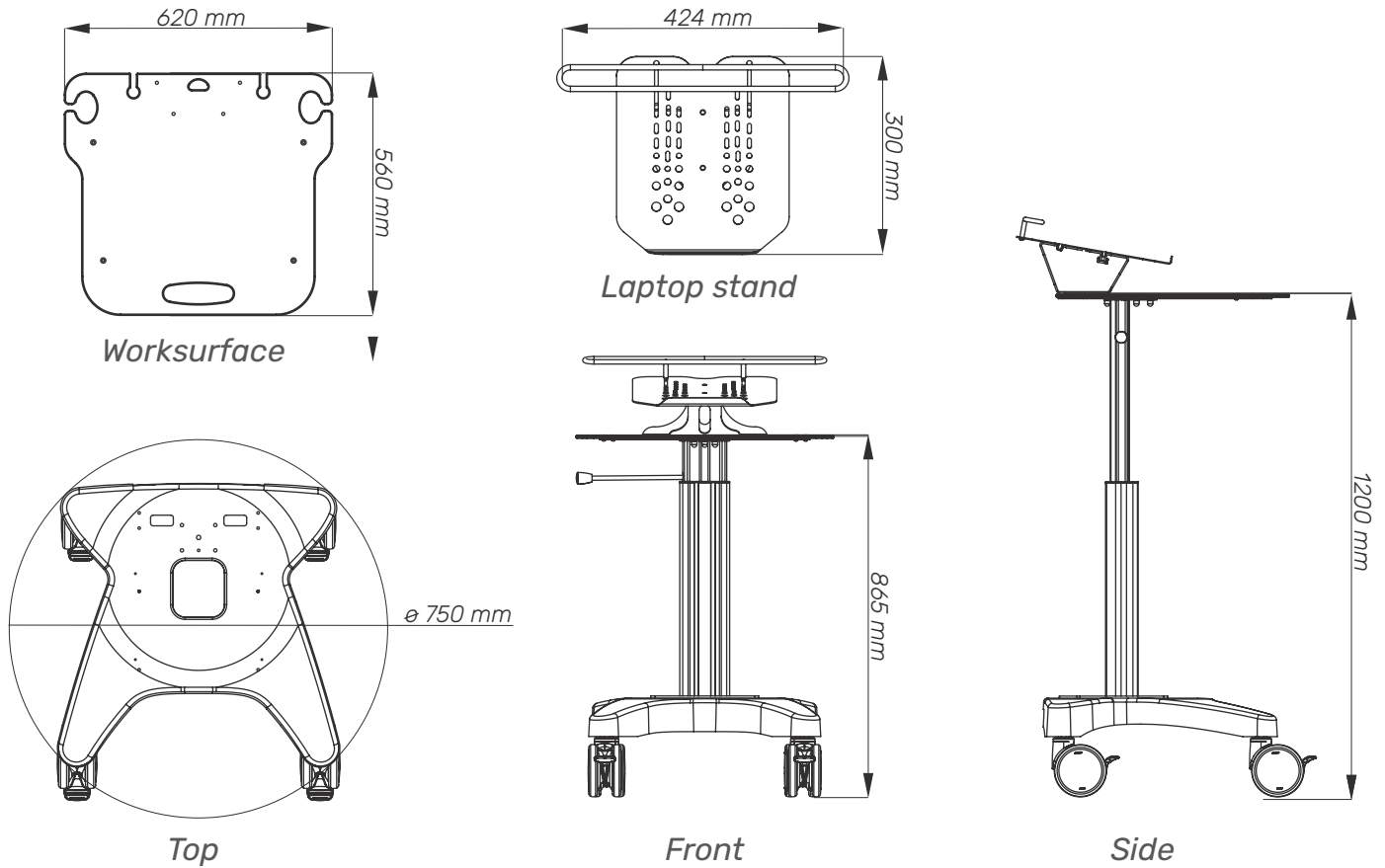

Mechanical data	
Height	Min.: 865 mm Max.: 1200 mm
Wheelbase dimension	750 mm (diameter)
Work surface dimensions	Width: 620 mm Height: 560 mm
Wheels/locking	2 lockable, 125mm diameter
Loading capacity	80 kg
Laptop stand	Width: 424 mm; Length: 300 mm
Construction	
Main material	Aluminium
Color	
RAL 9016	
Custom color	
Certificates	
Certificates conforms to	IEC60601-1:2012 (Edition 3)
CE	Rohs compliant