

RHI-4-E

Height adjustable cart with display mount and keyboardtray

Rhino Range



Ergonomic



Easy to clean



Multi purpose



Lifetime warranty



Quick setup



FEATURES



Designed and manufactured in Hungary, products are typically 100% recyclable and upgradable in the future. Raw materials are sourced locally or in the EU.

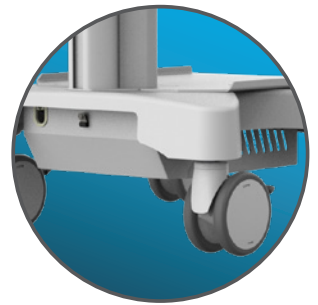

Isolation transformer holder



Tiltable, rotatable, height adjustable Display Mount

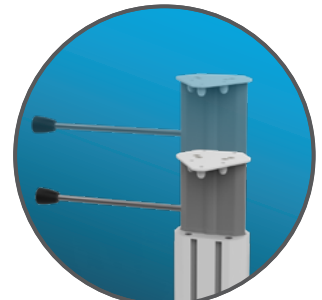

Height adjustment and column channels to fix accessories

Cart Properties

Dimensions and mechanical data

DIMENSIONS

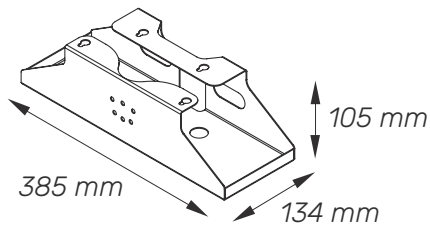

Power supply holder

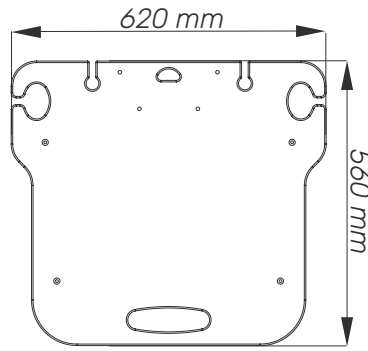

Worksurface

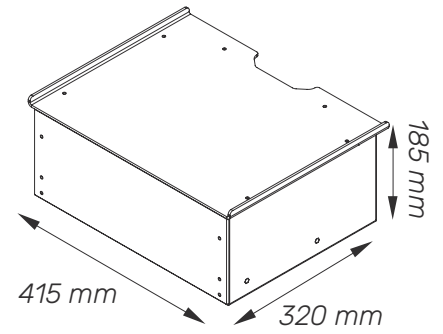

Drawer with shelf

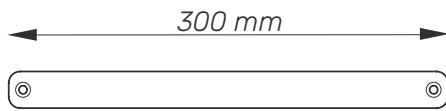

DIN Rail

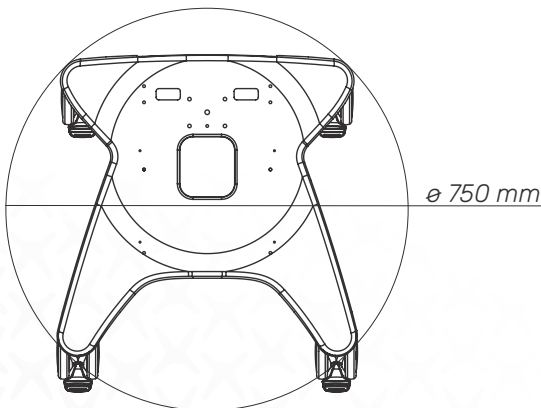

Base

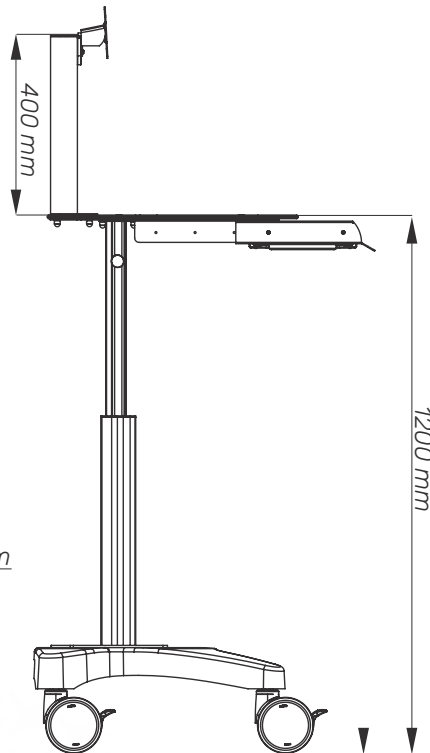

Side

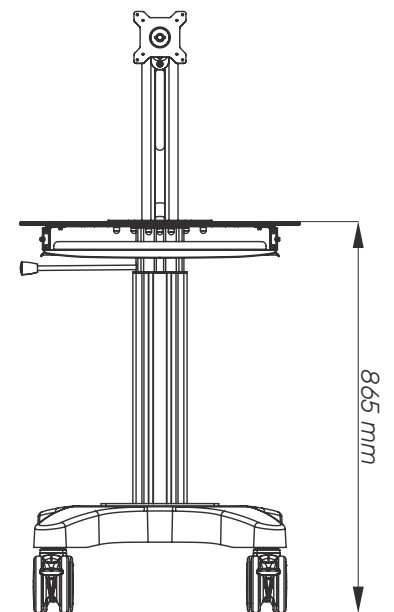

Front

Cart Properties

Dimensions and mechanical data

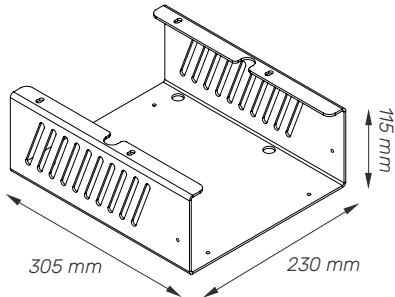

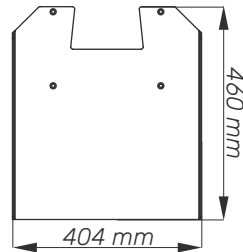

Isolation transformer holder

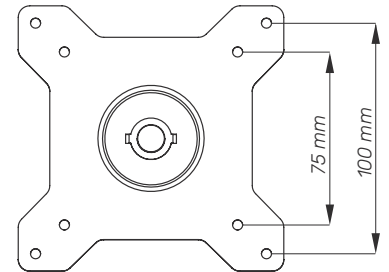

Shelf



VESA Mount up to 24"

Mechanical data	
Height	Min.: 865 mm Max.: 1200 mm
Wheelbase dimension	750 mm (diameter)
Work surface dimensions	Width: 620 mm Height: 560 mm
Wheels/locking	2 lockable, 125mm diameter
Loading capacity	80 kg
VESA Mount hole pattern	75x75 mm; 100x100 mm
VESA Mount load capacity	6-12 kg up to 24"
Power supply holder	134x105x385 mm
Drawer	415x185x320 mm
Isolation transformer holder	230x115x305 mm
DIN Rails	300 mm
Power funktions	
Battery technology	LiPo4
Battery capacity	240Wh or 512 Wh
Safety options	Charge indicator LED; Digital feedback on display
Construction	
Main material	Aluminium
Color	
RAL 9016	
Custom color	
Certificates	
Certificates conforms to	IEC60601-1:2012 (Edition 3)
CE	Rohs compliant